

Rotating Torque Sensor DR-2114 (contactless) with Rated Torque from 0.1 ... 20 N·m

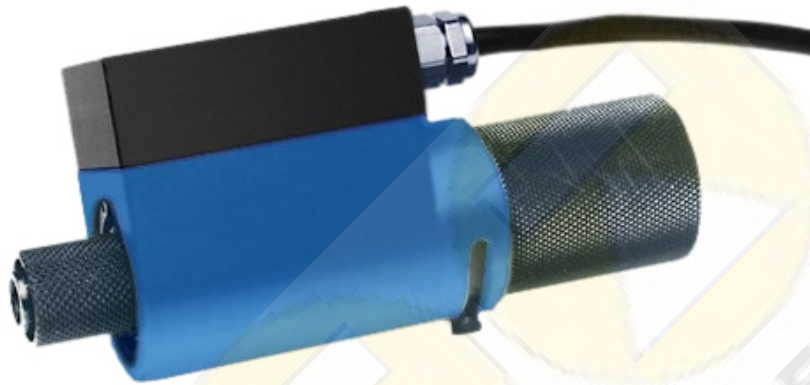

This sensor has a contactless and digital signal transmission from rotor to stator without signal falsification of the measurement data. It is therefore highly accurate and maintenance-free.

Performance Features

- Torque sensor for screw driving systems
- High accuracy
- Active output $\pm 5V$ (optional $\pm 10V$)
- Integrated speed/angle measurement, optional
- Speed up to 4000 min^{-1}
- Very short axial length
- High torsional stiffness
- Simple handling and assembly
- Special versions on request

Application

- Assembly technology
- Process measuring and control technology
- Automotive industry
- Measuring and control devices
- Tool engineering
- Special mechanical engineering

Dimensions of DR-2114 in mm

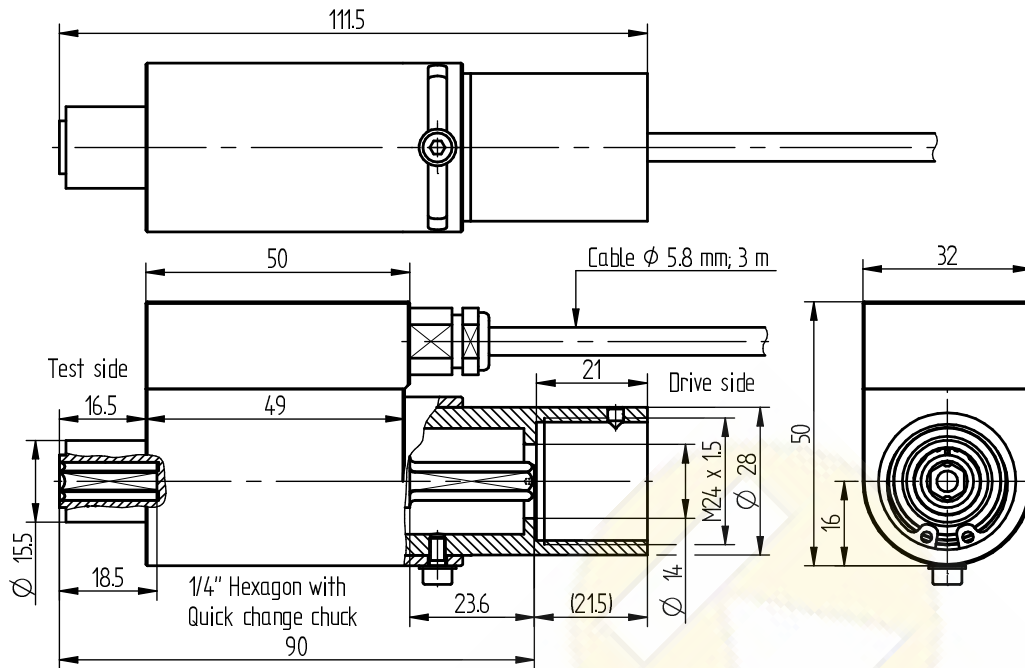

Rated Torque [N·m]	Hexagon Drive	Weight [kg]
0.1/0.2/0.5/1/2/5/10/15/20	1/4"	0.4

Connection Assignment

Electrical Connection			
Supply (+)	brown	●	12 ... 28VDC
Supply (GND)	green	●	0V
Signal (+)	yellow	●	±5V (±10V)
Signal (GND)	white	○	0V
Control signal	gray	●	L <2.0V; H >3.5V
Signal angle A (option)	pink	●	5V TTL
Signal angle B (option)	blue	●	5V TTL
NC	red	●	-
Shield	shield	⊕	



Technical Data acc. to VDI/VDE/DKD 2639

Torque Sensor DR-2114

Rated torque M_{nom}	N·m	0.1 ... 20
Accuracy class	% M_{nom}	0.1
Relative repeatability error in unchanged mounting position b'	% M_{nom}	±0.02
Rated range of supply voltage	VDC	12 ... 28
Current consumption	mA	≤60
Output signal	V	±5
Control signal excitation	V	L <2.0; H >3.5
Sample rate	kSample/s	10
Electrical connection		Cable, 3 m with free strands
Reference temperature T_{ref}	°C	23
Rated temperature range	°C	5 ... 45
Operating temperature range	°C	0 ... 60
Storage temperature range	°C	-10 ... 70
Temperature effect on zero signal TK_0	% $M_{nom}/10 K$	±0.2
Temperature effect on characteristic value TK_C	% $M_{nom}/10 K$	±0.1
Maximum operating torque M_G (static)	% M_{nom}	150
Torque limit M_{max} (static)	% M_{nom}	200
Breaking torque M_B (static)	% M_{nom}	>300
Permissible oscillation stress when subjected to torque M_{df}	% M_{nom}	70 (peak-to-peak)
Level of protection		IP50

Article-No.	Rated Torque [N·m]	Limit Speed [min ⁻¹]	Springrate [N·m/rad]	Mass Moment of Inertia [kg·m ²] ¹		Axial Force Limit [N] ²	Lateral Force Limit [N] ²
				Drive Side	Test Side		
103813	0.1	3000	1.8E+01	2.6E-06	2.7E-07	43	0.7
103812	0.2	3000	1.8E+01	2.6E-06	2.7E-07	58	1
103811	0.5	3000	1.1E+02	2.6E-06	2.7E-07	185	1.8
103810	1	4000	1.1E+02	2.6E-06	2.7E-07	255	2.9
103809	2	4000	3.0E+02	2.6E-06	2.7E-07	480	7.6
103808	5	4000	5.1E+02	2.6E-06	2.8E-07	880	18
101559	10	4000	5.8E+02	2.6E-06	3.0E-07	1150	27
103806	15	4000	5.8E+02	2.6E-06	3.0E-07	1150	27
103807	20	4000	5.8E+02	2.6E-06	3.0E-07	1150	27

Options

Article-No.	Description	
103562	Output signal	±10V
101560	Speed/angle measurement, 2 x 360 impulses, 90° displaced	5V TTL, CW-turn CH A  CH B 

¹ Without option speed/angle measurement

² Unsupported shaft

Calibrations

Article-No.	Description	
400676	Linearity diagram in accordance to factory standard	25 % steps
400664	Linearity diagram in accordance to factory standard	10 % steps
400961	Proprietary calibration acc. to VDI/VDE 2646	3 steps
400700	Proprietary calibration acc. to VDI/VDE 2646	5 steps
400688	Proprietary calibration acc. to VDI/VDE 2646	8 steps
401023	Proprietary calibration for the angle of rotation acc. to VDI/VDE 2648-1	
	DAkKS-Calibration/Standard on request	

Accessories

Electrical Connection

Article-No.	Description
10320	Cable connector KSSH15 (15-pin) incl. sensor mounting
10337	Cable connector KS12 (12-pin) incl. sensor mounting

Amplifiers

Examples of suitable amplifiers for the torque sensor DR-2114:

